

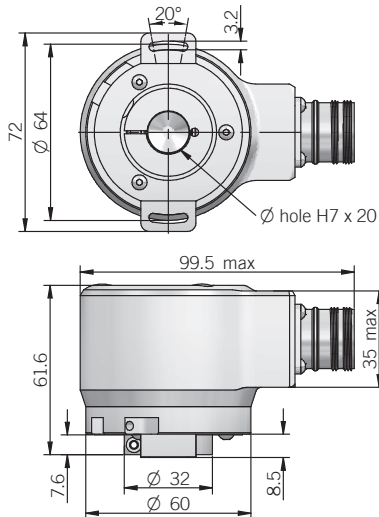

EA 58 F

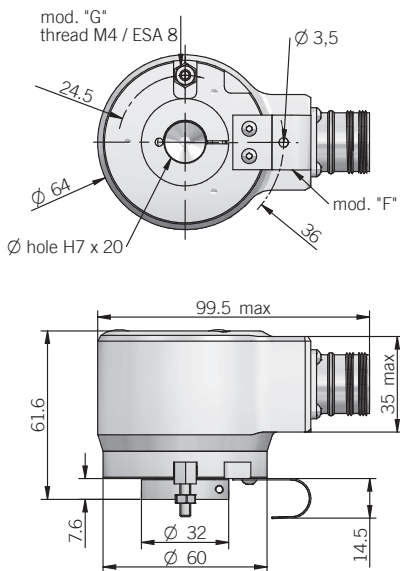

EA 63 F - G



anti-rotation pin is included in model G, for mounting instruction please refer to product installation notes

Dimensions with axial output

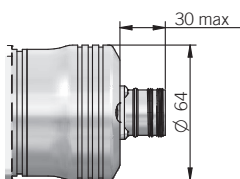

ELECTRICAL SPECIFICATIONS

Resolution	from 2 to 8192 ppr
Power supply	8/28 = 7,6 ... 29,4 V DC
Current consumption without load	100 mA
Max load current	20 mA / channel
Output type	P = push-pull (active short circuit protection)* S = RS-422
Auxiliary inputs	active high (+Vdc) connect to 0V if not used / Reset tmin 150 ms
Max frequency	output: 25 kHz LSB bit parallel clock input: 100 kHz ... 1 MHz SSI
SSI monostable time (Tm)	18 µs
SSI pause time (Tp)	> 35 µs
SSI frame	(MSB ... LSB) 13 bit data length
Accuracy	± 1/2 LSB
Counting direction	decreasing clockwise (shaft view)
Start-up time	150 ms
Electromagnetic compatibility	IEC 61000-6-2 IEC 61000-6-4

*output levels according to power supply, for further details please see under Technical basics section

MECHANICAL SPECIFICATIONS

Bore diameter	ø 8* / 9* / 10* / 12* / 14 / 15 mm
Enclosure rating	IP 54 (IEC 60529)
Max rotation speed	3000 rpm
Shock	50 G, 11 ms (IEC 60068-2-27)
Vibration	10 G, 10 ... 2000 Hz (IEC 60068-2-6)
Moment of inertia	5 x 10 ⁻⁶ kgm ²
Starting torque (at +20°C / +68°F)	< 0,02 Nm
Body material	EN-AW 2011 aluminum
Shaft material	1.4305 / AISI 303 stainless steel
Housing material	painted aluminum
Bearings	2 ball bearings
Bearings life	10 ⁹ revolutions
Operating temperature	0° ... +60°C (+32° ... +140°F)
Storage temperature	-15° ... +70°C (+5° ... +158°F)
Fixing torque for collar clamping	1,5 Nm recommended
Weight	450 g (15,87 oz)

* with supplied adapter shaft



BIT PARALLEL CONNECTIONS

Function	Binay / Gray	Cable output PD	Cable output PE	MA 19 pin
bit 1 (LSB)	B ⁰ / G ⁰	green	green	A
bit 2	B ¹ / G ¹	yellow	yellow	B
bit 3	B ² / G ²	blue	blue	C
bit 4	B ³ / G ³	brown	brown	D
bit 5	B ⁴ / G ⁴	orange or pink	orange or pink	E
bit 6	B ⁵ / G ⁵	white	white	F
bit 7	B ⁶ / G ⁶	grey	grey	G
bit 8	B ⁷ / G ⁷	purple	purple	H
bit 9	B ⁸ / G ⁸	gray / pink	gray / pink	J
bit 10	B ⁹ / G ⁹	white / green	white / green	K
bit 11	B ¹⁰ / G ¹⁰	brown / green	brown / green	L
bit 12	B ¹¹ / G ¹¹	white / yellow	white / yellow	M
bit 13	B ¹² / G ¹²	yellow / brown	yellow / brown	N
STROBE	/	/	green / blue	P
LATCH	/	/	yellow / grey	R
0 Volt	/	black	black	T
U / D	/	red / blue	red / blue	U
+ Vdc	/	red	red	V
⏏	/	shield	shield	S

SSI CONNECTIONS

Function	Cable output PC	7 pin MC	10 pin MD	12 pin HA	8 pin M12
+ Vdc	red	G	G	8	8
0 Volt	black	F	F	1	5
data +	green	C	C	2	3
data -	brown	D	D	10	2
clock +	yellow	A	A	3	4
clock -	orange or pink	B	B	11	6
RESET	white	/	H	4	1
U / D	red / blue	E	E	5	7
⏏	shield	housing	J	9	housing

MC connector (7 pin)
Amphenol MS3102-E-16-S
solder side view FV

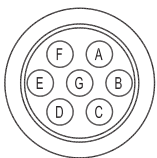

MD connector (10 pin)
Amphenol MS3102-E-18-1
solder side view FV

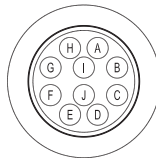

MA connector (19 pin)
Amphenol 62IN 12E 14-19 P
solder side view FV

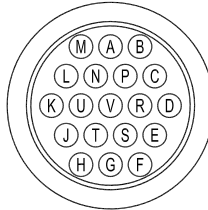

HA connector (12 pin) - M23 CCW
Hummel 7.410.000000 -
7.002.912.603
solder side view FV

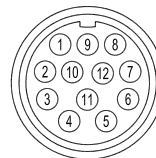

M12 connector (8 pin)
M12 A coded
solder side view FV

