

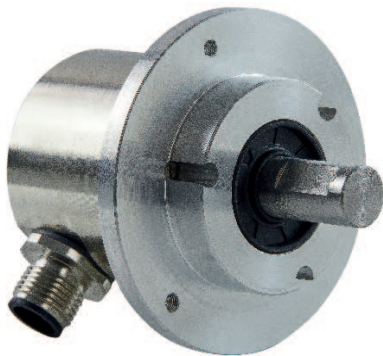

EAMW 58 B / C - 63 A / D SSI

SOLID SHAFT MAGNETIC MULTIURN ABSOLUTE ENCODER



Specifications

Industry standard multiturn absolute encoder for factory automation applications.

- Magnetic sensor technology without contact (Magnetic ASIC + Energy Harvesting)
- Up to 24 bit as total resolution (12 bit single turn + 12 bit multiturn)
- Power supply up to +30 VDC with SSI as electronic interface
- Code reset for easy setup
- Cable or connector output
- Solid shaft diameter up to 10 mm
- Mounting by synchronous, clamping or centering 2,5" square flange

ORDERING CODE	EAMW	58B	12 / 12	G	8/30	S	P	ZE	6	X	X	P	R	.XXX
<p>SERIES magnetic multiturn absolute encoder series EAMW</p> <p>MODEL synchronous flange ø 31.75 mm 63A synchronous flange ø 50 mm 58B clamping flange ø 36 mm 58C centering square flange ø 31.75 mm 63D</p> <p>MULTITURN RESOLUTION 12 bit</p> <p>SINGLETURN RESOLUTION 8 / 10 / 12 bit</p> <p>CODE TYPE binary B gray G</p> <p>POWER SUPPLY 8 ... 30 V DC 8/30</p> <p>ELECTRONIC INTERFACE Serial Synchronous Interface - SSI S</p> <p>LOGIC positive P</p> <p>OPTIONS reset ZE</p> <p>SHAFT DIAMETER (mod. 58 B) mm 6 (mod. 63 A / D) (9,52 mm 3/8") mm 9 (mod. 58 C - 63 A / D) mm 10</p> <p>ENCLOSURE RATING IP 67 cover side / IP 65 shaft side X</p> <p>OPTIONS to be reported X</p> <p>OUTPUT TYPE cable (standard length 0,5 m) P M12 connector M12 <i>female connector included, without female please add 162 as variant code</i></p> <p>DIRECTION TYPE radial R</p> <p>VARIANT custom version XXX</p>														



ELECTRICAL SPECIFICATIONS

Multiturn resolution	12 bit
Singleturn resolution	8 / 10 / 12 bit
Power supply	8/30 = 7,6 ... 30 V DC
Power draw without load	< 400 mW
Output type	RS-422
Code type	binary or gray
Auxiliary inputs (U/D - Reset)	active high (+Vdc) <i>connect to 0V if not used / Reset t_{min} 150 ms</i>
Clock frequency	100 kHz ... 1 MHz
SSI monostable time (Tm)	20 μ s
SSI pause time (Tp)	> 35 μ s
SSI frame	tree format (MSB ... LSB) 25 bit length (12MT + 12ST + '0')
Accuracy	$\pm 0,35^\circ$ typical
Counting direction	decreasing clockwise (shaft view)
Start-up time	150 ms
Electromagnetic compatibility	IEC 61000-6-2 IEC 61000-6-4

MECHANICAL SPECIFICATIONS

Shaft diameter	\varnothing 6 mm / 9,52 mm (3/8") / 10 mm
Enclosure rating	IP 67 cover side / IP 65 shaft side (IEC 60529)
Max rotation speed	6000 rpm continuous
Max shaft load	10 N axial / 20 N radial with \varnothing 6 shaft 100 N axial / radial
Shock	50 G, 11 ms (IEC 60068-2-27)
Vibration	20 G, 10 ... 2000 Hz (IEC 60068-2-6)
Moment of inertia	$0,5 \times 10^{-6}$ kgm ²
Starting torque (at +20°C / +68°F)	< 0,03 Nm
Shaft material	AISI 303 stainless steel
Housing material	AISI 420 stainless steel
Bearing stage material	EN-AW 2011 aluminium
Bearings	2 ball bearings
Bearings life	10 ⁹ revolutions
Operating temperature	-20° ... +85°C (-4° ... +185°F)
Storage temperature	-20° ... +85°C (-4° ... +185°F)
Weight	350 g (12,35 oz)

CONNECTIONS

Function	Cable output	8 pin M12 connector
+ Vdc	red	8
0 Volt	black	5
data +	green	3
data -	brown	2
clock +	yellow	4
clock -	orange or pink	6
U / D	red / blue	7
RESET	white	1
---	shield	housing

M12 connector (8 pin)
M12 A coded
solder side view FV

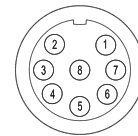

ACCESSORIES

set n.3 fixing clamps for model 58 B
P/N 94080001

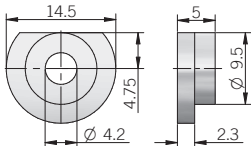

EAMW 63 A

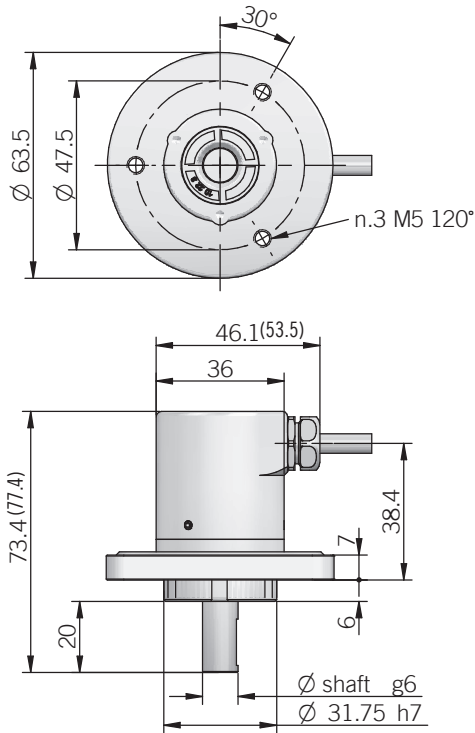

EAMW 58 B

fixing clamps not included

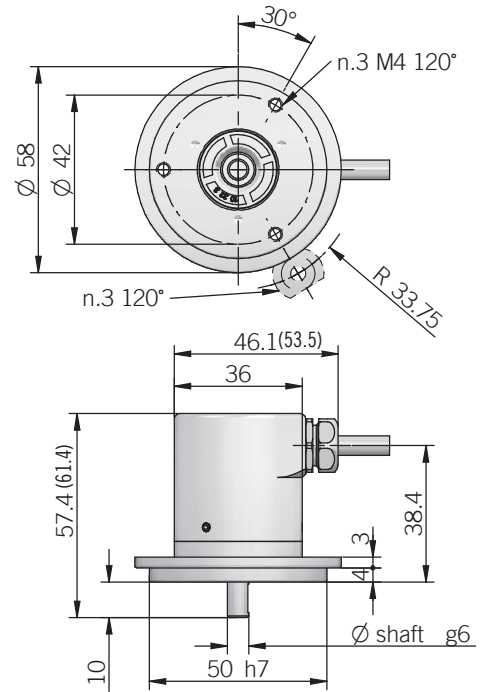

EAMW 58 C

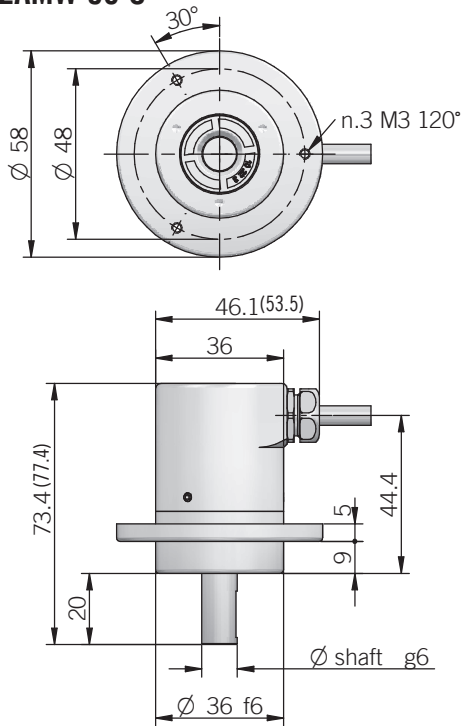

EAMW 63 D

