

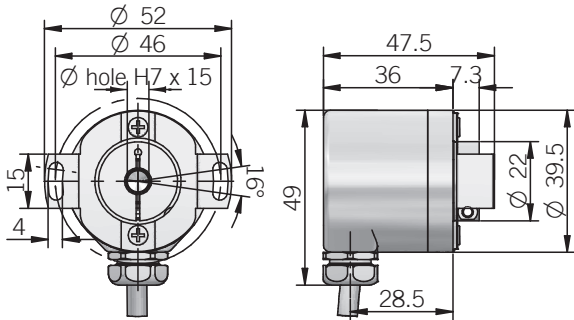

## EM - ER 38 F

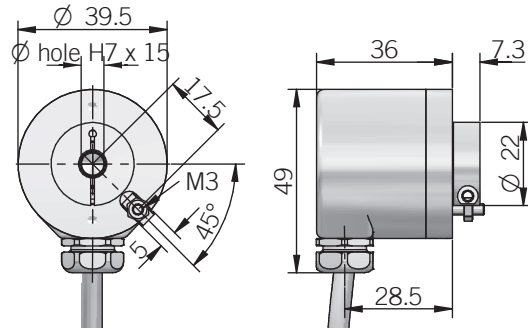

## EM - ER 38 G



### ELECTRICAL SPECIFICATIONS

<b>Sensing principle</b>	magnetic Asic (EM) / reflective OptoAsic (ER)
<b>Resolution</b>	from 1 to 14400 ppr
<b>Power supply</b>	5 = 4,5 ... 5,5 V DC 5/30 = 4,5 ... 30 V DC (reverse polarity protection)
<b>Power draw without load</b>	5 = 200 mW typical 5/30 = 600 mW typical
<b>Max load current</b>	20 mA / channel
<b>Output type*</b>	NPN / NPN open collector push-pull / line driver
<b>Max output frequency</b>	250 kHz up to 3600 ppr / 500 kHz from 4000 ppr
<b>Counting direction</b>	A leads B clockwise (shaft view)
<b>Startup time</b>	150 ms
<b>Electromagnetic compatibility</b>	EC 61000-6-2

\*output levels according to power supply, for further details please see under Technical basics section

### EM SERIES RESOLUTIONS

1 - 2 - 4 - 5 - 6 - 10 - 15 - 16 - 20 - 30 - 32 - 40 - 50 - 70 - 80 - 90

### ER SERIES RESOLUTIONS

100 - 120 - 128 - 200 - 240 - 250 - 256 - 300 - **360** - 400 - 480 - **500** - **512** - 600 - 625 - 720 - 800 - 900 - **1000** - **1024** - 1200 - 1250 - 1440 - 1800 - **2000** - **2048** - **2500** - 3000 - **3600** - 4000 - 4096 - **5000** - 6000 - **7200** - 8000 - 8192 - 10000 - 12000 - 14400

please directly contact our offices for other pulses, preferred resolutions in bold

### MECHANICAL SPECIFICATIONS

<b>Bore diameter</b>	ø 6* / 8* / 10 mm
<b>Enclosure rating</b>	IP 65 (IEC 60529)
<b>Max rotation speed</b>	6000 rpm
<b>Max shaft load</b>	5 N axial / radial
<b>Shock</b>	50 G, 11 ms (IEC 60068-2-27)
<b>Vibration</b>	10 G, 10 ... 2000 Hz (IEC 60068-2-6)
<b>Moment of inertia</b>	0,8 x 10 <sup>-6</sup> kgm <sup>2</sup>
<b>Starting torque (at +20°C / +68°F)</b>	< 0,01 Nm
<b>Fixing torque for collar clamping</b>	0,6 Nm recommended
<b>Body material</b>	EN-AW 2011 aluminum
<b>Shaft material</b>	1.4305 / AISI 303 stainless steel
<b>Housing material</b>	painted aluminum
<b>Bearings</b>	2 ball bearings
<b>Bearings life</b>	10 <sup>9</sup> revolutions
<b>Operating temperature</b>	-25° ... +85°C (-13° ... +185°F)
<b>Storage temperature</b>	-25° ... +85°C (-13° ... +185°F)
<b>Weight</b>	150 g (5,29 oz)

\* with supplied adapter shaft

### CONNECTIONS

Function	Cable output N / C / P	Cable output L / RS
+V DC	red	red
0 V	black	black
Ch. A	green	green
Ch. A-	/	brown
Ch. B	yellow	yellow
Ch. B-	/	orange
Ch. Z	blue	blue
Ch. Z-	/	white
⏏	shield	shield