

EMI 40 A radial cable output

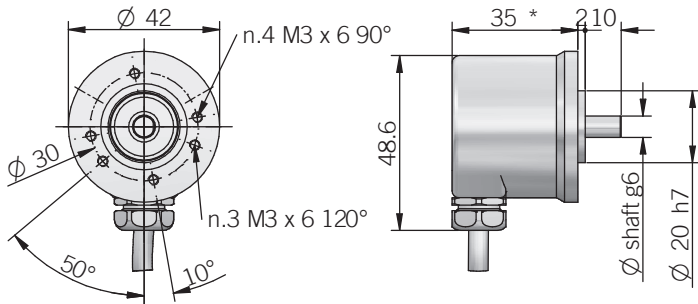

Dimensions with axial cable output

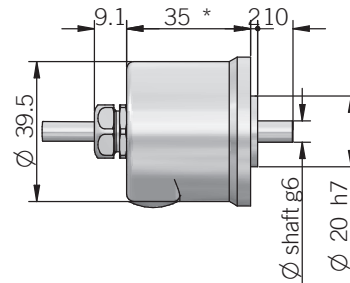

* IP66 + 7mm

ELECTRICAL SPECIFICATIONS

Resolution	from 2 to 2048 ppr
Power supply	5 = 4,5 ... 5,5 V DC 5/28 = 4,75 ... 29,4 V DC 8/24 = 7,6 ... 25,2 V DC (reverse polarity protection)
Current consumption without load	80 mA max
Max load current	15 mA / channel
Output type*	push-pull / line driver
Max output frequency	205 kHz
Counting direction	A leads B clockwise (shaft view)
Accuracy	$\pm 0,35^\circ$ typical / $\pm 0,50^\circ$ max
Electromagnetic compatibility	IEC 61000-6-2 IEC 61000-6-4

*output levels according to power supply, for further details please see under Technical basics section

RESOLUTIONS

2 - 4 - 8 - 10 - 16 - 20 - 32 - 40 - 64 - 80 - 100 - 125 - 128 - 200 - 250 - 256 - 400 - 500 - 512 - 1024 - 2048

please directly contact our offices for other pulses

CONNECTIONS

Function	Cable output Push-pull	Cable output Line driver
+V DC	red	red
0 V	black	black
Ch. A	green	green
Ch. A-	/	brown
Ch. B	yellow	yellow
Ch. B-	/	orange
Ch. Z	blue	blue
Ch. Z-	/	white
\equiv	shield	shield

MECHANICAL SPECIFICATIONS

Shaft diameter	$\varnothing 4 / 6$ mm
Enclosure rating	X = IP 64 (IEC 60529) S = IP 66 (IEC 60529)
Max rotation speed	3000 rpm (IP 66) 6000 rpm (IP 64)
Max shaft load	5 N axial / radial
Shock	50 G, 11 ms (IEC 60068-2-27)
Vibration	10 G, 10 ... 2000 Hz (IEC 60068-2-6)
Moment of inertia	$0,5 \times 10^{-6}$ kgm ²
Starting torque (at +20°C / +68°F)	< 0,02 Nm
Body material	EN-AW 2011 aluminum
Shaft material	1.4305 / AISI 303 stainless steel
Housing material	painted aluminum
Bearings	2 ball bearings
Bearing lifetime	10 ⁹ revolutions
Operating temperature	-25° ... +100°C (-13° ... +212°F)
Storage temperature	-25° ... +85°C (-13° ... +185°F)
Weight	150 g (5,29 oz)