

EPLB

CYLINDRICAL LINEAR POTENTIOMETER



Specifications

EPLB is an absolute linear potentiometer transducer. Mechanical mounting is made simpler by the presence of two spherical joints on the two sides and by the enclosure's cylindrical shape. The main characteristic is the absence of variations on the electrical output signal outside of the theoretical electrical stroke. Thanks to its robustness and precision EPLB represents a great solution in most mechanical application for automation.

ORDERING CODE	EPLB	300	S	5	P	R
SERIES cylindrical linear potentiometer model EPLB						
STROKE mm from 50 to 750 <i>see table for stroke availability</i>						
ENCLOSURE RATING IP 65 S						
TRAVEL SPEED max speed 5 m/s 5						
OUTPUT TYPE cable (standard length 1 m) P 3 pin connector C3 DIN 43650-C 4 pin connector C4 M16 DIN 45322 5 pin connector C5						
OUTPUT DIRECTION radial R						

EPLB

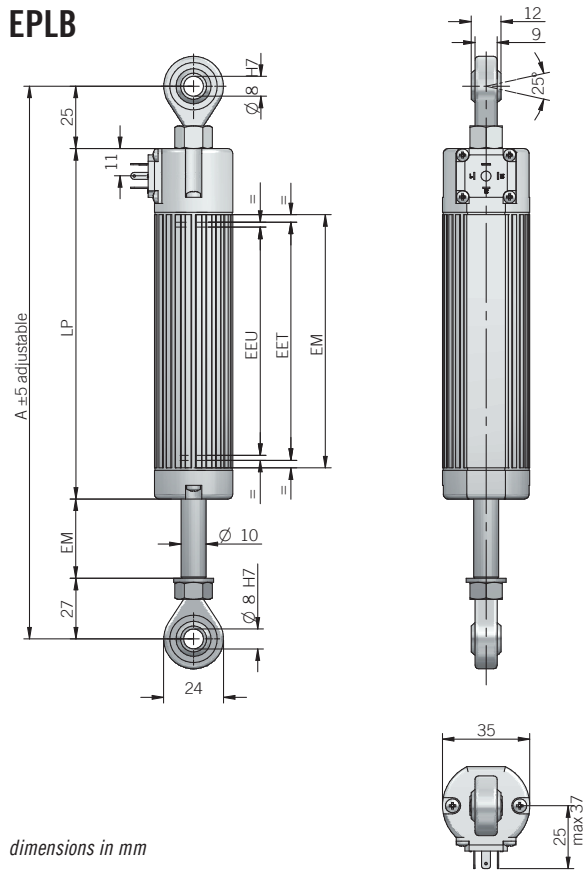

dimensions in mm

· female connector not included, for ordering P/N please refer to Accessories section

CONNECTIONS

Function	Cable output	3 pin C3 output	4 pin C4 output	5 pin C5 output
+	blue	3	3	3
-	brown	1	1	1
output	yellow	2	2	2
nc	/	/	/	/
nc	/	/	/	/
⊥	shield	/	⊥	/

C3 connector (3 pin)

solder side view FV

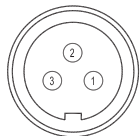

C4 connector (4 pin)

DIN 43650-C solder side view FV

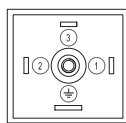

C5 connector (5 pin)

DIN 45322 solder side view FV

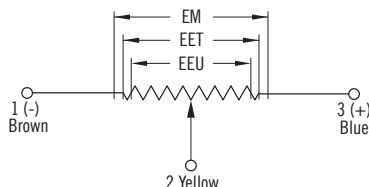
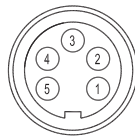

ELECTRICAL SPECIFICATIONS

Resolution	virtually infinite
Independent linearity	$\pm 0,05 \%$
Repeatability	0,01 mm
Resistance tolerance	$\pm 20 \%$
Recommended cursor current	$< 0,1 \mu\text{A}$
Output voltage temperature coefficient	$\leq 1,5 \text{ ppm} / ^\circ\text{C}$
Power dissipation	3 W at 40°C / 0 W at 120°C
Max cursor current	10 mA
Applicable voltage	60 V max
Electrical insulation	$> 100 \text{ M}\Omega$, 500 VDC, 1 bar, 2 s
Dielectric strenght	$< 100 \mu\text{A}$, 500 VAC, 50 Hz, 1 bar, 2 s

Important: datas are valid if the transducer is used as a ratiometric device with a maximum applicable current $\leq 0,1 \mu\text{A}$.

MECHANICAL SPECIFICATIONS

Stroke	50 - 100 - 150 - 200 - 300 - 400 - 450 - 500 - 600 - 750 mm
Useful electric stroke (EEU) (+3/-0 mm)	see model (mm)
Theoretical electric stroke (EET) (± 1 mm)	EEU + 3 mm (50 ... 150), EEU + 4 mm (200 ... 300), 406 mm (400), 457 mm (450), 508 mm (500), 609 mm (600), 762 mm (750)
Mechanical stroke (EM)	EEU + 9 mm (50 ... 150), EEU + 10 mm (200 ... 300), 412 mm (400), 463 mm (450), 518 mm (500), 619 mm (600), 772 mm (750)
Resistance (on the EET)	5 k Ω (50 ... 600) 10 k Ω (750)
Case length (LP)	EEU + 129 mm (50 ... 150), EEU + 130 mm (200 ... 300), 538 mm (400), 589 mm (450), 664 mm (500), 765 mm (600), 918 mm (750)
Minimum interaxis length (A)	EEU + 177 mm (50 ... 150), EEU + 178 mm (200 ... 300), 586 mm (400), 637 mm (450), 712 mm (500), 813 mm (600), 966 mm (750)
Travel speed	5 m/s max En-
closure rating	IP 65 (IEC 60529)
Shock	50 G, 11 ms (IEC 60068-2-27)
Vibration	20 G, 5 ... 2000 Hz (IEC 60068-2-6)
Displacement force	$\leq 15 \text{ N}$
Moving angle	$\pm 25^\circ$ max
Housing material	anodized aluminium / Nylon 66 G
Rod material	1.4305 / AISI 303 stainless steel
Mounting	n° 2 selfloading and selfaligning ball-joints
Life	$> 25 \times 10^6$ m strokes or $> 100 \times 10^6$ manoeuvres
Operating temperature	$-30^\circ \dots +100^\circ\text{C}$ ($-22^\circ \dots +212^\circ\text{F}$)
Storage temperature	$-50^\circ \dots +120^\circ\text{C}$ ($-58^\circ \dots +248^\circ\text{F}$)

Installation warning instructions:

- connect the transducer according to the reported connections
- DO NOT use it as a variable resistance
- the transducer calibration has to be done setting the stroke in order to have an output signal between 1% and 99% of the voltage level