



EPLC

RODLESS LINEAR POTENTIOMETER



Specifications

EPLC is an absolute linear potentiometer transducer without internal rod. This transducer is characterized by a cursor with integrated coupling sliding on the axis. The main characteristic is the absence of variations on the electrical output signal outside of the theoretical electrical stroke.

ORDERING CODE	EPLC	500	X	4	C4	A
SERIES rodless linear potentiometer model EPLC						
STROKE mm from 100 to 1500 <i>see table for stroke availability</i>						
ENCLOSURE RATING IP 40 X						
TRAVEL SPEED max speed 10 m/s 4 max speed 10 m/s 10						
OUTPUT TYPE DIN 43650-A 4 pin connector C4 M16 DIN 43322 5 pin connector C5						
OUTPUT DIRECTION axial A						

EPLC

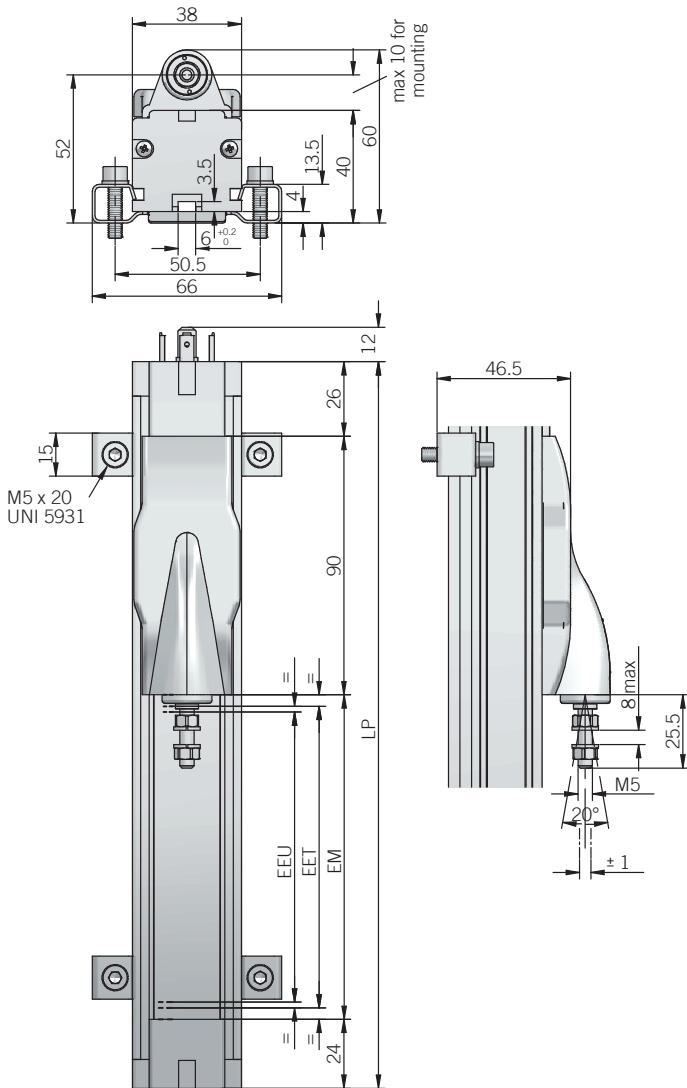

dimensions in mm

· fixing kit (brackets, screws, grower) included

· female connector not included, for ordering P/N please refer to Accessories section

CONNECTIONS

Function	Cable output	4 pin C4 output	5 pin C5 output
+	blue	3	3
-	brown	1	1
output	yellow	2	2
nc	/	/	/
nc	/	/	/
⊥	shield	⊥	/

C4 connector (4 pin)
DIN 43650-C
solder side view FV

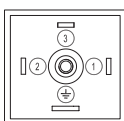

C5 connector (5 pin)
DIN 45322
solder side view FV

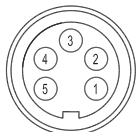

Important: datas are valid if the transducer is used as a ratiometric device with a maximum applicable current $\leq 0,1 \mu\text{A}$

ELECTRICAL SPECIFICATIONS

Resolution	virtually infinite
Independent linearity	$\pm 0,05 \%$
Repeatability	0,01 mm
Resistance tolerance	$\pm 20 \%$
Recommended cursor current	$< 0,1 \mu\text{A}$
Resistance temperature coefficient	-200 ... 200 ppm / °C typical
Output voltage temperature coefficient	$\leq 5 \text{ ppm} / ^\circ\text{C}$ typical
Power dissipation	3 W at 40 °C / 0 W at 120 °C
Max cursor current	10 mA max
Applicable voltage	60 V max
Electrical insulation	$> 100 \text{ M}\Omega$, 500 VDC, 1 bar, 2 s
Dielectric strenght	$< 100 \mu\text{A}$, 500 VAC, 50 Hz, 1bar, 2 s

MECHANICAL SPECIFICATIONS

Stroke	100 - 150 - 200 - 300 - 400 - 500 - 600 - 700 - 850 - 900 - 1000 - 1250 - 1500 mm
Useful electric stroke (EEU) (+3/-0 mm)	see model (mm)
Theoretical electric stroke (EET) ($\pm 1 \text{ mm}$)	103 mm (100), 153 mm (150), 204 mm (200), 305 mm (300), 406 mm (400), 509 mm (500), 611 mm (600), 713 mm (700), 865 mm (850), 915 mm (900), 1017 mm (1000), 1271 mm (1250), 1521 mm (1500)
Mechanical stroke (EM)	EET + 10mm (100 ... 1500)
Resistance (on the EET)	5 k Ω (100 ... 300) 10 k Ω (400 ... 1000) 20 k Ω (1250 ... 1500)
Case length (LP)	EET + 150mm (100 ... 1500)
Travel speed	4 = 4 m/s max 10 = 10 m/s max
Acceleration	200 m/s ² max
Enclosure rating	IP 40 (IEC 60529)
Shock	50 G, 11 ms (IEC 60068-2-27)
Vibration	20 G, 5 ... 2000 Hz (IEC 60068-2-6)
Displacement force	$\leq 1,2 \text{ N}$ max
Housing material	anodized aluminium / Nylon 66 G 25
Mounting	brackets with variable center-to-center distance with M6 screw ISO4017 - DIN933
Operating temperature	-30° ... +100°C (-22° ... +212°F)
Storage temperature	-50° ... +120°C (-58° ... +248°F)

ELECTRICAL CONNECTIONS

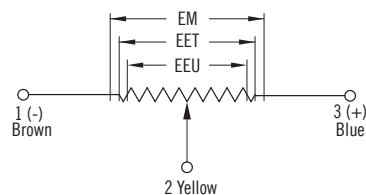

Installation warning instructions:

- connect the transducer according to the reported connections
- DO NOT use it as a variable resistance
- the transducer calibration has to be done setting the stroke in order to have an output signal between 1% and 99% of the voltage level