

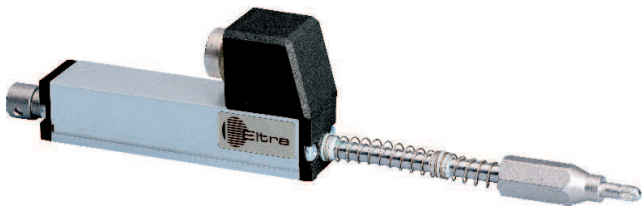

EPLT

LINEAR POTENTIOMETER WITH BALL TIP



Specifications

EPLT is an absolute linear potentiometer transducer. This model is characterized by the absence of cursor and the presence of a sensing system, composed by a moving rod, stainless steel sphere mounted on a threaded tip with a spring. This transducer is suitable for applications where short strokes are requested. The presence of the spring assures an automatic head positioning making this device suitable for being used in precise applications on cams or to control products coming from automatic production line. EPLT is also characterized by the absence of variations on the electrical output signal outside of the theoretical electrical stroke.

ORDERING CODE	EPLT	100	X	10	P	A
SERIES linear potentiometer with ball tip EPLT						
STROKE 10 / 25 / 50 / 75 / 100 <i>please contact our offices for other strokes</i>						
ENCLOSURE RATING IP 40 X						
TRAVEL SPEED max speed 10 m/s 10						
OUTPUT TYPE cable (standard length 1 m) P M16 DIN 43322 5 pin connector C5						
OUTPUT DIRECTION axial A						

EPLT

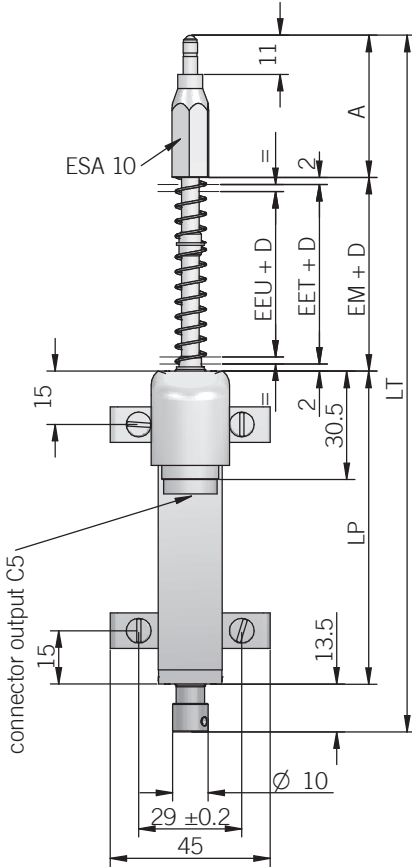
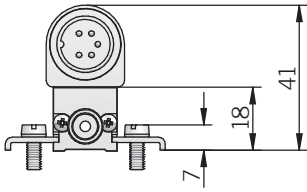

dimensions in mm

- fixing kit (brackets, M4x10 screws, washer) and tip with ball included
- female connector not included, for ordering P/N please refer to Accessories section

CONNECTIONS

Function	Cable output	5 pin C5 output
+	blue	3
-	brown	1
output	yellow	2
nc	/	/
nc	/	/
⊥	shield	/

C5 connector (5 pin)
DIN 45322
solder side view FV

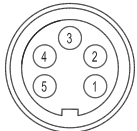

Important: datas are valid if the transducer is used as a ratiometric device with a maximum applicable current $\leq 0,1 \mu\text{A}$

ELECTRICAL SPECIFICATIONS

Resolution	virtually infinite					
Stroke	mm	10	25	50	75	100
Independent linearity	%	$\pm 0,3$	$\pm 0,2$	$\pm 0,1$	$\pm 0,1$	$\pm 0,1$
Resistance tolerance	$\pm 20 \%$					
Recommended cursor current	$< 0,1 \mu\text{A}$					
Output voltage temperature coefficient	$< 1,5 \text{ ppm} / ^\circ\text{C}$					
Power dissipation at 40 °C (0 W at +120 °C)	W	0,2	0,6	1,2	1,8	2,4
Max cursor current	10 mA max					
Max applicable voltage	V	14	25	60	60	60
Electrical insulation	$> 100 \text{ M}\Omega$, 500 VDC, 1 bar, 2 s					
Dielectric strenght	$< 100 \mu\text{A}$, 500 VAC, 50 Hz, 1bar, 2 s					

MECHANICAL SPECIFICATIONS

Stroke	mm	10	25	50	75	100
Useful electric stroke (EEU) (+1/-0 mm)	mm	10	25	50	76	101
Theoretical electric stroke (EET) (± 1 mm)	mm	11	26	51	76	101
Mechanical stroke (EM)	mm	15	30	55	81	106
Resistance (on EET)	k Ω	1	1	5	5	5
Case length (LP)	mm	48	63	88	114	139
Sensing probe length	mm	32	32	40	40	40
Additional length (D)	mm	-	-	-	5	11
Total length (LT)	mm	108	138	196	251	307
Travel speed	10 m/s max En-					
closure rating	IP 40 (IEC 60529)					
Shock	50 G, 11 ms (IEC 60068-2-27)					
Vibration	20 G, 5 ... 2000 Hz (IEC 60068-2-6)					
Displacement force	$\leq 4 \text{ N}$					
Housing material	anodized aluminium / Nylon 66 G 25					
Rod material	1.4305 / AISI 303 stainless steel					
Mounting	brackets with variable center-to-center distance					
Life	$> 25 \times 10^6$ m strokes or $> 100 \times 10^6$ operations					
Operating temperature	$-30^\circ \dots +100^\circ\text{C}$ ($-22^\circ \dots +212^\circ\text{F}$)					
Storage temperature	$-50^\circ \dots +120^\circ\text{C}$ ($-58^\circ \dots +248^\circ\text{F}$)					

ELECTRICAL CONNECTIONS

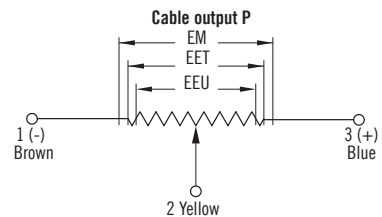

Installation warning instructions:

- connect the transducer according to the reported connections
- DO NOT use it as a variable resistance
- the transducer calibration has to be done setting the stroke in order to have an output signal between 1% and 99% of the voltage level